

American Rescue Plan Act (ARPA)

	Amount Totals
ARPA Funds Total	\$34,150,391.00
Loss Revenue Total	\$12,908,307.00
GrantWorks Contract Fee	\$1,160,000.00
Total Remaining	\$20,082,084.00

Approved CC Date: 12/13/2021

All Requests \$250,000 and Under

Non-Profit Organizations

Name	Project Name	Amount Requested	Amount Approved	Approval Date	Paid
✓ Children's Advocacy Center	Covid Recovery Project	\$250,000.00			
✓ Chisholm Trail Outdoor Museum	Needed Improvements at Museum, Cleburne	\$245,000.00			
✓ We Are ReInspire	Losses Due to Covid Impact	\$153,000.00			
✓ Pecan Valley Centers	Facility Modifications	\$150,000.00			
✓ Crazy8 Ministries	Connection/Training Center for our Residents	\$147,000.00			
✓ Bread Connection	Updating Van & Warehouse Equipment	\$105,500.00			
✓ H.I.M. Center Food Bank	H.I.M. Mobile Pantry Project	\$65,000.00			
✓ Promises Community Ministry	Hope Starts Here	\$59,244.54			
✓ Crazy8 Ministries	Refurbishing a Single Wide	\$48,000.00			
✓ Johnson County Family Crisis Center	Road Repaving	\$30,000.00			
✓ Crazy8 Ministries	Main Campus Foundation Repair	\$22,096.00			
✓ Cleburne Friends of the Cultural Arts	Revenue Recovery for 2020	\$21,000.00			
✓ Johnson County Crime Stoppers	Produce Video & Printing School Posters	\$20,000.00			
✓ HOPE Clinic Cleburne	Refurbishing of Existing Clinic Space	\$10,000.00			
✓ HOPE Clinic Cleburne	Replacing Old Computers	\$10,000.00			
✓ Court Appointed Special Advocate (CAS)	Volunteer Recruitment Campaign	\$7,000.00			
✓ Answer International	Website, Promotional Items & Office Equip.	\$5,050.00			
***Open Door Ministries	4 - 1,000 ft. Walk In Coolers/Freezers	\$180,000.00			
***Open Door Ministries	Metal Fencing to Secure Property	\$58,000.00			
***Open Door Ministries	2 - Forklifts	\$42,000.00			
		\$1,627,890.54	\$0.00		

American Rescue Plan Project Submission Form

Project Name - A short name for your project, such as "Sewer Line Expansion along Main St."

Covid Recovery Project

Primary Point of Contact - The name and contact information for the person in your organization that should be contacted first about this project for more details.

Tammy King, Executive Director for the Children's Advocacy Center

O: 817-558-1599 C: 817-933-3839 tammyking@cacjctx.org

1304 Country Club Road, Cleburne, Texas 76033

Project Description - A description of your project or item for purchase in 250 words or less, including why the project is needed and how that need will be met.

Due to recent conversations with Grant Works, we were advised to re-submit our application for financial losses rather than capital since our building project is nearly done. During Covid our fundraising efforts have been severely impacted. The total loss based on three-year averages of events prior to covid equals \$234,225.34. In addition to these losses, we also faced the challenge of decreased donations. From 2019 to 2020, individual and private foundation gifts dropped 37% (\$97,394.25). Losses from fundraising events and drops in individual/foundation gifts, totaled a loss of \$331,619.59. Replacing funds that were lost would help us to ensure that we can continue to deliver services during a time when we are facing an extreme increase in demand for mental health services. During Covid our suicidality rates jumped from 33% to 47.88%. We have been working to secure grant funding for additional Therapists to address these need as well as drastically increasing our clinical intern program.

Project Location - Where your project will be performed, such as "500 feet along Main Street". Include maps, if available.

The Children's Advocacy Center is located at 1304 Country Club Road in Cleburne. All of our trauma informed services take place at this location.

Project Budget - A rough estimate of the budget required for your project.

In our original application, we were asking for \$250,000 to go toward the Covid 19 adaptations made to our building. With that in mind, we will only be asking for \$250,000 of the lost funds.

Project Timeframe - An estimate of how long it will take to start the project, how long the project will take to complete, and how long it will take to expend all funds related to the project.

We have continued to provide all services for child victims, but we were having to place some on a therapy wait list due to the incredible demand we were facing. We recently secured one grant to hire a group facilitator and we are actively growing our intern program. We are still down two full time staff positions that we lost during Covid. Being able to replenish some of our operating funds will help us to supply such things as therapy supplies and food for kids and families attending evening group therapy sessions. It would also help us purchase sensory play therapy equipment and supplies for our kids with special needs. We are constantly seeking out grants to assist us with operational funding to provide special activities for the children, so we will continue to actively seek out funding for such things as prevention and outreach and a summer safety camp that we host for our kids.

As far as a timeline, we are working hard to have no interruption of services and to improve on what we can offer through our new location. We depleted a reserve account the Board of Directors worked so hard to put into place in case a crisis situation occurred, so we could continue to operate. We are so grateful that they worked so hard over the years to ensure there was a safety net for such a time as this.

Rachel Sitler

From: Tammy King <tammyking@cacjctx.org>
Sent: Tuesday, January 25, 2022 10:09 AM
To: kevin.dyer@grantworks.net; County Judge (public address)
Subject: FW: American Rescue Plan Project Submission Form
Attachments: JCCAC American Rescue Plan Project Submission Form.PDF

Some people who received this message don't often get email from tammyking@cacjctx.org. [Learn why this is important](#)

*** External sender - use caution with links or attachments ***

Good Morning Kevin and Judge Harmon,

Please find attached the submission form for the Children's Advocacy Center. We would welcome a visit to the Center, so you can see firsthand how we have worked to address Covid 19 issues in the design of our new building. There will also be Open House Invitations going out this afternoon. Open House for the community will be on February 8, 2022. We are still trying to complete the approach, nature trails, some of the flooring and of course the wonderful punch list, but we do have our Temporary Certificate of Occupancy and have moved in to the new location.

We look forward to hearing from you. Have a great day!

Tammy King
Executive Director
Children's Advocacy Center
817-558-1599
tammyking@cacjctx.org
www.cacjctx.org



Our mission is to provide each child who has suffered abuse with justice, hope and healing.

This e-mail message is intended only for the named recipient(s) above and is covered by the Electronic Communications Privacy Act 18 U.S.C. Section 2510-2521 and Health Insurance Portability and Accountability Act of 1996, (P.L.104-191). This email and any files transmitted with it are confidential and intended solely for the use of the individual or entity to whom they are addressed. If you have received this email in error please notify the system manager. This message contains confidential information and is intended only for the individual named. If you are not the named addressee you should not disseminate, distribute or copy this e-mail. Please notify the sender immediately by e-mail if you have received this e-mail by mistake and delete this e-mail from your system. If you are not the intended recipient you are notified that disclosing, copying, distributing or taking any action in reliance on the contents of this information is strictly prohibited.

American Rescue Plan Project Submission Form

Project Name - A short name for your project, such as "Sewer Line Expansion along Main St."

Children's Advocacy Center's Covid Relief Building Modifications Project

Primary Point of Contact - The name and contact information for the person in your organization that should be contacted first about this project for more details.

Tammy King, Executive Director
817-558-1599

tammyking@cacjctx.org

Project Description - A description of your project or item for purchase in 250 words or less, including why the project is needed and how that need will be met.

The Children's Advocacy Center was in the middle of their "Forever Home Capital Campaign" when Covid 19 hit. Our architect at the time was working on a building design that would allow staff to have their own offices. We had 3 in offices. When Covid hit we decided to add sliding glass walls in all Therapist's offices and Family Rooms. These doors would open into courtyards allowing for indoor/outdoor sessions + bringing in fresh air. We also implemented a nature trail, so it can be used for outdoor sessions as well.

Project Location - Where your project will be performed, such as "500 feet along Main Street". Include maps, if available.

1304 Country Club Road, Cleburne, TX 76033

10 1/2 acre location

Project Budget - A rough estimate of the budget required for your project.

Total Construction Cost is about 3.5 million. The cost to complete these modifications is over \$400,000. We are requesting \$250,000.

Project Timeframe - An estimate of how long it will take to start the project, how long the project will take to complete, and how long it will take to expend all funds related to the project.

The building is almost completed. We just got the sliding glass doors in place using a bridge loan. The courtyards are also complete. The nature trail is still under way.

Rachel Sitrler

From: Tammy King <tammyking@cacjctx.org>
Sent: Thursday, April 7, 2022 4:56 PM
To: Kevin Dyer; County Judge (public address)
Subject: Children's Advocacy Center-ARPA Application
Attachments: CACJC.pdf

Categories: ARPA

Some people who received this message don't often get email from tammyking@cacjctx.org. [Learn why this is important](#)

*** External sender - use caution with links or attachments ***

Hi Kevin and Judge Harmon,

After discussion with Grant Works and our new building, it was decided that we should submit based on lost funds during Covid rather than the building, since the building is essentially completed. It turns out the figure for loss funds was actually higher, but we are submitting for the same amount. Thank you both for what you do! I have attached the new application.

Tammy King
Executive Director
Children's Advocacy Center
1304 County Club Road
Cleburne, Texas 76033
817-558-1599
tammyking@cacjctx.org
www.cacjctx.org



Our mission is to provide each child who has suffered abuse with justice, hope and healing.

This e-mail message is intended only for the named recipient(s) above and is covered by the Electronic Communications Privacy Act 18 U.S.C. Section 2510-2521 and Health Insurance Portability and Accountability Act of 1996, (P.L.104-191). This email and any files transmitted with it are confidential and intended solely for the use of the individual or entity to whom they are addressed. If you have received this email in error please notify the system manager. This message contains confidential information and is intended only for the individual named. If you are not the named addressee you should not disseminate, distribute or copy this e-mail. Please notify the sender immediately by e-mail if you have received this e-mail by mistake and delete this e-mail from your system. If you are not the intended recipient you are notified that disclosing, copying, distributing or taking any action in reliance on the contents of this information is strictly prohibited.

January 1, 2022

To: Johnson County Commissioners' Court: Judge Roger Harmon

American Rescue Plan Project Submission Form

Project Name: Needed Improvements at Chisholm Trail Outdoor Museum (CTOM), Cleburne.
Primary Point of Contact: Johnson County Heritage Foundation, a Non-Profit 501(c)(3) Corp. 101 Chisholm Trail, PO Box 771, Cleburne, Texas 76033 Tax ID: 27-0114146
David Murdoch, CEO/Chairman 817 648 1486 Carrie Reynolds, On-Site Director 254 998 0261

Project Description: CTOM has seen increased Visitation over the last two years, despite COVID. We have several events in 2022 that will attract large crowds and CTOM needs improvement in infrastructure and sewage. Currently having to use PORT-A-Potties, inadequate & unsanitary and funding to promote and handle tourism. Needs exist this year and into the future.

1.) Waste Management System Systems (Investment in Infrastructure meets ARPA criteria)

A.) Construct of Restroom Building with sewage system to adequately handle larger crowds visiting CTOM. \$48,000. *(a)

B.) Construction of Cabins (5) each with waste management systems to accommodate tourist/visitor requests and provide operational revenue. $\$25,000 \times 5 = \$125,000$. (includes \$7500 per cabin for WMS systems.) *(b)

2.) Signage: (To promote economic recovery meets ARPA criteria)

A.) Electronic Marque to announce CTOM events: 5' x 20' \$50,000. *(c)

B.) Smaller, "billboard" signs placed along highway advertising CTOM. 4 @ \$1000.

3.) Loss of Revenue (Meets ARPA Criteria due to COVID lost revenue.

In 2020 and 2021, closed 10 weekends or 30 days 33 visitor/day @ \$8.00 each = \$8000.

4.) Teepees: (To promote economic recovery meets ARPA criteria) Replace Canvas and poles, 3 teepees @ 3,300 each = \$10,000. (RO)

Project Location: All projects listed will be performed on-site within the boundary of CTOM, except signage along Hwy 67 nearby directing visitors to CTOM.

Project Budget: Requires \$245,000.

Project Timeframe: With this funding, all projects can be completed within six months of receiving funds. The projects listed are urgent to handle the needs of the increasing visitors and scheduled events at CTOM. We anticipate up to 30,000+ visitors in 2022 on weekends and major events: Texas Independence Day (Mar); Santa Fe Days on the Trail (Apr); Blue Grass Festival (Apr); Pioneers Days (Nov); Cowboy Christmas (Dec)

Submitted by: David Murdoch

Carrie Reynolds

Footnotes: (a) and (b) Blueprints and specs available: (c) Estimated costs and example of another governmental agency using ARPA funds promotion tourism: (d) CTOM Factsheet

Rachel Sitler

From: Paula G. Reid
Sent: Wednesday, February 2, 2022 10:31 AM
To: Kevin Dyer; County Judge
Cc: David Murdoch
Subject: ARPA Funding Request
Attachments: Chisholm Trail.pdf

Please see the attached request for ARPA funding for the Chisholm Trail Outdoor Museum.

Thank you,

Paula Reid

Administrative Assistant to
County Judge Roger Harmon
2 N Main, RM 120
Cleburne, Texas 76033
817-556-6360

American Rescue Plan Project Submission Form

Project Name - *A short name for your project, such as "Sewer Line Expansion along Main St."*

Losses due to Covid Impact

Primary Point of Contact - *The name and contact information for the person in your organization that should be contacted first about this project for more details.*

Charise Olson, Executive Director
ChariseO@WeAreReInspire.org
817-405-9178
PO Box 2792, Cleburne, TX 76033

Project Description - *A description of your project or item for purchase in 250 words or less, including why the project is needed and how that need will be met.*

ReInspire is applying for assistance due to losses we experienced in 2020 -2021 due to Covid. These losses continue to impact our ability to serve in 2022. ReInspire was established in 2017 (IRS Status in Feb 2018). We are based in Johnson County and serve vulnerable teens and young adults in Johnson County. Our clients are youth aging out of foster care, youth who have been homeless, or experienced other adverse experiences that act as obstacles to success and stability. As a still-growing and rather new nonprofit, we entered 2020 with a lot of momentum from two successful county-wide fundraisers and other work we had done to build our revenue streams in 2019. In March of 2020, this momentum seemed to disappear overnight. However, we never closed our doors. Needs for our services increased dramatically as our young clients experienced the pandemic. In fact, ReInspire expanded services as other agencies closed and we responded to the needs of our young people. We continued to have costs and expenses with no income. ReInspire relies solely on grants, donations, and fundraisers to operate. Every area of income was impacted and greatly reduced, in some cases to 0. Successful fundraisers take years to build. The impact of 2020 only served to increase the losses- and burden- for 2021. We are still feeling the effects in 2022. These funds would allow us to recover financially as we continue to serve the youth in our communities.

Project Location - *Where your project will be performed, such as "500 feet along Main Street". Include maps, if available.*

ReInspire is based in and serves Johnson County.

Project Budget - *A rough estimate of the budget required for your project.*

\$153,000 (2020, 2021 only)

Project Timeframe - *An estimate of how long it will take to start the project, how long the project will take to complete, and how long it will take to expend all funds related to the project.*

These funds would provide a sense of security we have not had since February 2020. This funding would allow us to continue and expand our services. We intend to serve the teens and young adults of Johnson County as long as they need us.

Paula G. Reid

From: Charise Olson <ChariseO@wearereinspire.org>
Sent: Sunday, April 3, 2022 2:44 PM
To: Kevin Dyer; County Judge (public address)
Subject: ARPA Application for Covid Losses
Attachments: Funding_ARPAFunding_2022.pdf

Categories: ARPA

Some people who received this message don't often get email from chariseo@wearereinspire.org. [Learn why this is important](#)

*** External sender - use caution with links or attachments ***

Hello,
Please find our attached application for ARPA funds due to Covid-related losses in 2020-2021. While we continue to feel the effects in this first quarter of 2022, those are not currently reflected in the application. I'll wait for clarification if 2022 can be included.

This application is meant to replace our application for the Resource Center per the guidance from Kevin at Grantworks.

We are scheduled to present before the Commissioners on April 13 (for Launchpads, young adult housing). Please let me know if I should include this application information in that presentation as well.

Thank you.
Best,
~Charise

Charise Olson
Executive Director, ReInspire
(817) 405-9178

Hope. Services. Connection.
WeAreReInspire.org

This email was sent by ReInspire and may contain sensitive information. Please use caution before forwarding. Personal Identifying Information is confidential and must be protected. If you receive this email by mistake, please notify us and delete the message.

American Rescue Plan Project Submission Form

Project Name-

Facility Modifications for Behavioral/Physical Health Primary Care

Point of Contact-

Coke Beatty, Executive Director, cbeatty@pecanvalley.org, 254.434.1158

2101 West Pearl, St, Granbury Tx 76048

Project Description-

Pecan Valley Centers (PVC) is the Local Mental Health Authority as designated by Texas Health and Human Services Commission for Johnson County and is responsible for access and treatment to those Serious Mental Illness. PVC is accredited by CARF International and by Texas HHSC as a Certified Community Behavioral Health Clinic. We request funds to modify the Cleburne Clinic to expand our Behavioral Health services to begin providing Primary Health Care to those with mental illness. The project will consist of adding plumbing, replacing flooring, painting walls, add a security door, and repair cosmetic interior needs to the existing behavioral health clinic which is approximately 15,000 sq. ft. These building modifications will assure a functional and safe medical facility and increase access to behavioral/physical health care. This building is owned by Johnson Co. and leased to PVC.

PVC is a recent recipient of a SAMSHA Grant to hire staff to provide physical primary health care within our behavioral health clinic. The funds we seek from Johnson County ARPA funds are for facility modifications that are required to provide this service. There aren't enough funds in the SAMSHA Grant to complete the facility modifications.

It is well documented the toll the Pandemic is having our communities. Even more so for persons with mental health and physical health concerns. Mental Health America published 2022 Key Findings. That report 19.86% of adults experienced a mental illness, nearly 50 million. Depression, Suicide are on the rise. Individuals are not seeking primary health care due to Covid-19 restrictions thus minor illnesses are exacerbated. Primary Care Clinics and Emergency Rooms have restricted access to services due to Covid-19 have negative effects on public health. Expanding our behavioral health clinic to include primary health care will help mitigate this health crisis in Johnson County and increase prevention moving forward.

Project Location-

1601 North Anglin Street, Cleburne, Tx 76031

Project Budget-

\$150,000.00

Project Timeframe-

The project could start in February with an anticipated completion by April. All funds would be expended during this fiscal year.

Rachel Sittler

From: Beatty, Coke <coke@pecanvalley.org>
Sent: Tuesday, January 11, 2022 9:55 AM
To: kevin.dyer@grantworks.net; County Judge (public address)
Cc: Paula G. Reid
Subject: ARPA Funding Request
Attachments: American Rescue Plan Project Submission Form.pdf

*** External sender - use caution with links or attachments ***

Good morning, Kevin!

Please find attached our request for proposed funding to make necessary facility modifications to enable us to provide physical health primary care within our behavioral health outpatient clinic in Cleburne. This would serve Johnson County residents that are in our services diagnosed with a serious mental illness. As of December 2021 we are currently serving 1,169 adults. We have bids on most of the work requested.

Thank you for this opportunity and If you have any questions please feel free to contact me.

Best Regards,

Coke

Coke Beatty / Executive Director

Pecan Valley Centers
2101 West Pearl St. / Granbury Tx 76048
Email / cbeatty@pecanvalley.org
Office / 817-579-4401
Fax / 866.312.0601
Mobile / 254-434-1158

www.pecanvalley.org

24-Hour Crisis & Intake Appointments: 1-800-772-5987



This e-mail and any files transmitted with it are the property of Pecan Valley Centers, are confidential, and are intended solely for the use of the individual or entity to whom this e-mail is addressed. If you are not one of the named recipient(s) or otherwise have reason to believe that you have received this message in error, please notify Pecan Valley Centers at 817-579-4422 or mailadmin@pecanvalley.org and delete this message from your computer. Any other use, retention, dissemination, forwarding, printing, or copying of this e-mail is strictly prohibited.

American Rescue Plan Project Submission Form

Project Name - A short name for your project, such as "Sewer Line Expansion along Main St."

Connection/Training Center for our Residents

Primary Point of Contact - The name and contact information for the person in your organization that should be contacted first about this project for more details.

Lisa Schwarz, 817-798-3441
lisa@crazy8ministries.com

Project Description - A description of your project or item for purchase in 250 words or less, including why the project is needed and how that need will be met.

Our Crazy8 Ministries main campus has a 2,000sq ft metal building on it that we need to make into a community space where all our residents and staff can meet at the same time. We currently must meet with residents one campus at a time. It is our desire to improve the community of our program and among residents by creating a space where we can all fellowship and have our holiday meals and parties together. In addition, we have educational trainings and speakers who come and empower our residents in things such as, finances, vocational and educational opportunities, nutrition, relationships, etc. At this point, we simply have no place to host these with more than 15-20 residents at a time.

With the growth of our resident capacity, it is necessary that we have a large space where we can fit all our residents for such events.

We also are hosting more and more classes on marriage, communications, parenting, grief, addiction, etc. not just for residents, but also for the community and our counseling clients. This center would open the door for even more classes at a higher capacity.

Project Location - Where your project will be performed, such as "500 feet along Main Street". Include maps, if available.

1100 W FM 917
Joshua, TX 76058

The building is in the back of the main office.

Project Budget - A rough estimate of the budget required for your project.

We have been working on getting bids and have received one that came in at \$147,000.

Project Timeframe - An estimate of how long it will take to start the project, how long the project will take to complete, and how long it will take to expend all funds related to the project.

As a board, we want to start moving forward on this project in 2022. This includes casting the vision, raising funds and starting to build. Our "push goal" is to have it built by the end of 2022[?]

The Bread Connection
American Rescue Plan Project
Submission Form

Becky Hightower: Executive Director
The Bread Connection
408 West Henderson Cleburne, Texas
PO Box 813 Keene, Texas
(469) 456-1885
Thebreadconnection50@gmail.com

American Rescue Plan Submission Form

Project Name:

Updating Van and Warehouse Equipment

Primary Point of Contact:

Becky Hightower

817-239-4547

hightower.becky@yahoo.com

Project Description:

The Bread Connection functions as a warehouse model food bank, that means we service and assist other charitable organizations. The majority of this food from our donors (mostly grocery stores) is delivered to the many charitable organizations located in and around Johnson County. Prior to the covid outbreak we were feeding an estimated 2 thousand people per month. After the outbreak, that number has increased to well over 10 thousand people per month. Having said that, our 1999 van is worn out. Which has resulted in us having to use the founder's personal truck. Although helpful, the truck does not offer near the carrying capacity that we need to keep up with the increasing demand. That is why it is imperative that we secure a new vehicle in order to continue providing this vital service. The community of people that we are serving grows by the week; and with the rising gas prices and inflation the need for our services will only continue to rise. We are now moving an estimated 11 tons of food monthly. A majority of this food arrives at our warehouse by truck and for this reason we are also asking for a walk behind forklift to further assist in our efforts.

Charitable organizations that we deliver food to include: Operation Blessing, Harvest House, Alvarado Helping Hands for Jesus, Fort Worth Hope Center, New Life Ministry, Broken Pieces Ministry, Family Crisis Center, Keene Community Food Distribution, East Cleburne Community Center, Clean Slate, Serenity, No Turning Back Ministry, Happy Hill Farm, SWAU Student Pantry, Buena Vista, and Fireside Trails.

Project Location:

Our building and warehouse are located at 408 West Henderson in Cleburne, Texas.

Project Budget: \$105,500

Est. Van Cost \$45,825 @ 2 = \$91,650

Est. Forklift Cost \$13,850

Total Project Cost \$105,500

Project Time Frame: Ongoing

SUMMARY

\$45,825

ESTIMATED NET PRICE ⁵⁹

\$779

PER MONTH FOR 60 MONTH FINANCE ⁵⁰

Custom Order Explained

Pre-production model shown throughout

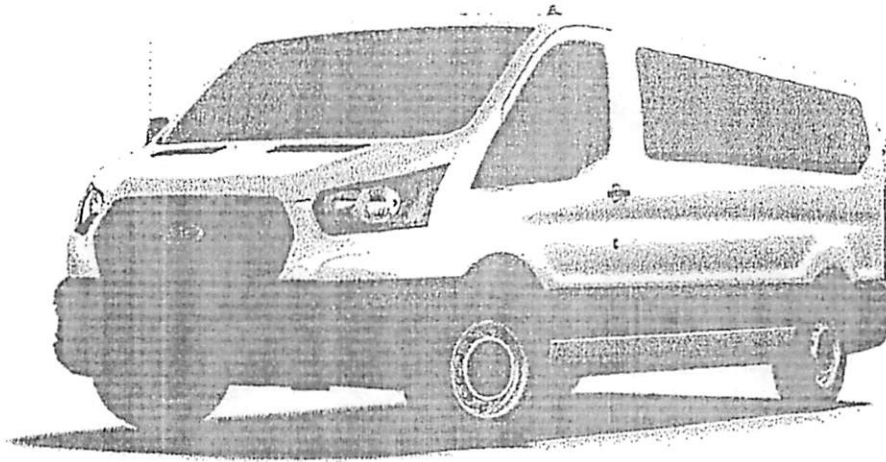

EXTERIOR ^{S4}

Oxford White	\$0
16" Steel Wheels with Full Silver Wheel Cover	\$35
235/65R16C 121/119 R BSW All-Season Tires	\$0
Short Arm Power Adjusting, Manual-Folding Mirrors	\$0
Windows – Tinted Glass	\$0
Spare Tire and Wheel	\$0
Roof Marker Lamp Delete	\$0
Windows – Fixed Glass, All-Around	\$0

Pre-production model shown throughout

POWERTRAINS ^{S4}

3.5L PFDI V6 Engine	\$0
Rear-Wheel Drive	\$0
10-Speed SelectShift® Automatic Transmission	\$0
3.73 Non-Limited Slip Axle	\$0

Custom Order Explained

PRICING SUMMARY

BASE MSRP ^{S1}	\$42,600
OPTIONS ^{S4} & ACCESSORIES ^{S8}	+ \$1,530
DESTINATION CHARGES ^{S17}	+ \$1,695
TOTAL MSRP ^{S16}	= \$45,825
ESTIMATED NET PRICE ^{S5}	= \$45,825
MONTHLY PAYMENT ^{S5}	\$779

Finance based on \$4,583 down payment,
60 month term and 5% APR, \$0 trade-in-value

YOUR ZIP CODE 76033

CLOSEST FORD DEALER

Cleburne Ford

6.58 miles away

(833) 748-5994

Your Configuration:

Pricing shown for Zip code 76033 as of March 10, 2022

DISCLOSURES 

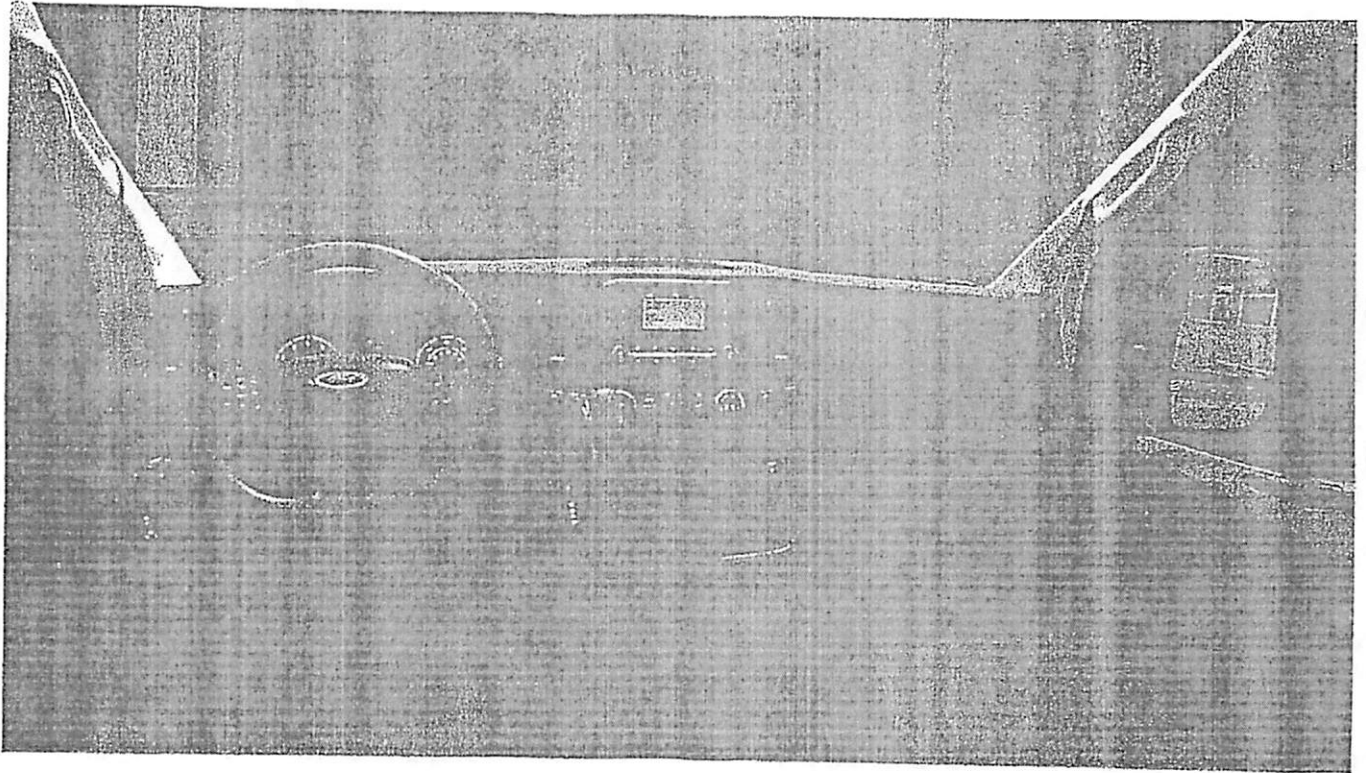

INTERIOR ^{S4}

Ebony	\$0
Ebony Cloth, 2-Way Manual Driver and 2-Way Manual Passenger Seats	\$0
Floor Covering – Front and Rear Vinyl	\$0
Illuminated Sun Visor	\$0
B-Pillar Assist Handle (Low Roof)	\$0
Rearview Mirror	\$0
Seat Configurations – Fifteen (15) Passenger	\$1,495
Front and Rear Auxilliary A/C and Heater	\$0
Full Rear Compartment Lighting	\$0
4" Multi-Function Display with AM/FM Stereo	\$0



Prepared By:
 Ross Bradley
 Abilene TX 79601 USA
 VBar Equipment Co.
 6298 E I-20
 (325) 400-5993

Created On: 03/16/2022

Quoted Price:
\$ 13,850.00

2022 BIG JOE PDS25-106 PDS25-106

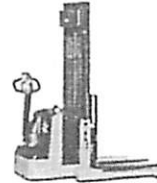
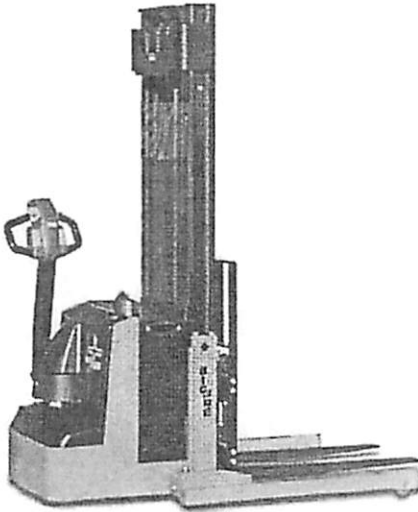

Big Joe PDS25-106 \$13,200 - Base Price \$11,600 Maint Free Battery 4 pack inc charger \$1,600 42" Forks, 36" Back rest - Checking on Lead Time, The 130 is generally in stock and ads \$200

List Price	\$ 13,200.00
Quoted Price	\$ 13,200.00
Shipping	\$ 650.00
Tax	\$ 0.00
Total	\$ 13,850.00

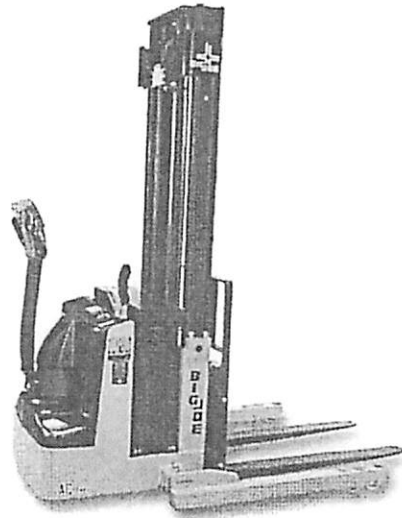

PDS25

Power Drive Straddle Truck

SHORT TURNING RADIUS MAKES THE PDS AN EXCELLENT CHOICE FOR NARROW AISLES, TOOL ROOMS OR STREET LOADING APPLICATIONS

CAPACITY

2500 lbs. at 24" load center

BATTERY

Compartment: 26.37" x 9.06" x open. Anderson 175 Gray—A-11 Minimum battery weight 340 lbs.

SPEED

24-volt ZAPI ACO Travel Controller

TRAVEL

Variable from 0 mph to 3.4 mph empty
Variable from 0 mph to 3.1 mph loaded

LIFT

Up to 30.9 fpm empty.
Up to 17.6 fpm loaded

LOWERING

Up to 18.4 fpm empty.
Up to 17.8 fpm loaded

WEIGHT

1943 lbs. Chassis Only

TIRES / WHEELS

DRIVE

9" x 3" polyurethane

DUAL LOAD

(2) 3.9" x 2" polyurethane

HYDRAULICS

Lift cylinder is hard chrome. Pump unit includes motor, gear pump, and solenoid. Pressure compensated lowering valves regulates lowering speeds.

ELECTRICAL

ZAPI AC travel controller and AC drive motor provides high torque throughout the entire drive range. Regenerative braking and brushless design drastically reduces maintenance.

Travel speed remains constant relative to throttle position regardless of the load on truck. Automatic resetting circuit breaker and one piece micro switch design complete the system.

BRAKES

Electromagnetic brake is mounted on motor armature shaft multiplying the braking power through the ZF GK10 transmission.

Brake is applied when control arm is in the vertical or horizontal handle position. Travel speed is reduced when forks are above 12" fork height. Position hold resists roll back on ramps.

CONTROLS

Travel, lift, and lower functions are located in the ergonomic operator handle, designed to allow operation with either hand. Wrap around guard, reversing switch, thumb control, and horn are standard.

Crawl speed function while steer handle is slightly back-tilted from vertical. This allows for easy maneuvering at reduced travel speeds in tight places.

TRANSMISSION

Vertically mounted drive motor is direct mounted to gear housing. Oil bathed bevel gear drive-train transfers power to axle. State of the art optimized gear technology supplies advantages such as zero maintenance, low noise level, high efficiency and high performance.

FRAME AND MAST

Bolt-on high visibility I-beam construction, lift cylinders are positioned in outer I-beam for good operator visibility through mast. Dual lifting chains.

Three inch wide adjustable straddle legs allow easy operation in racked aisles. Straddle leg inside dimension (ID) can be set at 38" to 50" in 4" increments; 42" to 50" with the triple stage mast

Class two ITA fork carriage with 36" tall load back rest.

BEARINGS

DRIVE WHEEL-Tapered roller bearings sealed in oil bath

LOAD WHEELS-Sealed ball bearings

ACCESSIBILITY

Removal of two piece power head cover exposes major components for inspection and maintenance. Drive wheel is removed with one nut.

STANDARD EQUIPMENT

- Adjustable Straddle Legs
- 3" Wide Straddle Leg
- Regenerative Braking
- Creep Speed Handle Control
- Gas Assist Spring Handle
- Low Battery Interrupt
- Hour Meter BDI Combo Gauge
- Key Switch

OPTIONAL EQUIPMENT

- 48" tall load backrest
- Cold conditioning
- Four Pack Power MF 224 AH / 5.4 kwh 110VAC plug-in charger
- Industrial Battery 255 AH 5.9 kwh

PDS 2500 Lbs. Capacity Power Drive Straddle Truck

DIMENSIONS

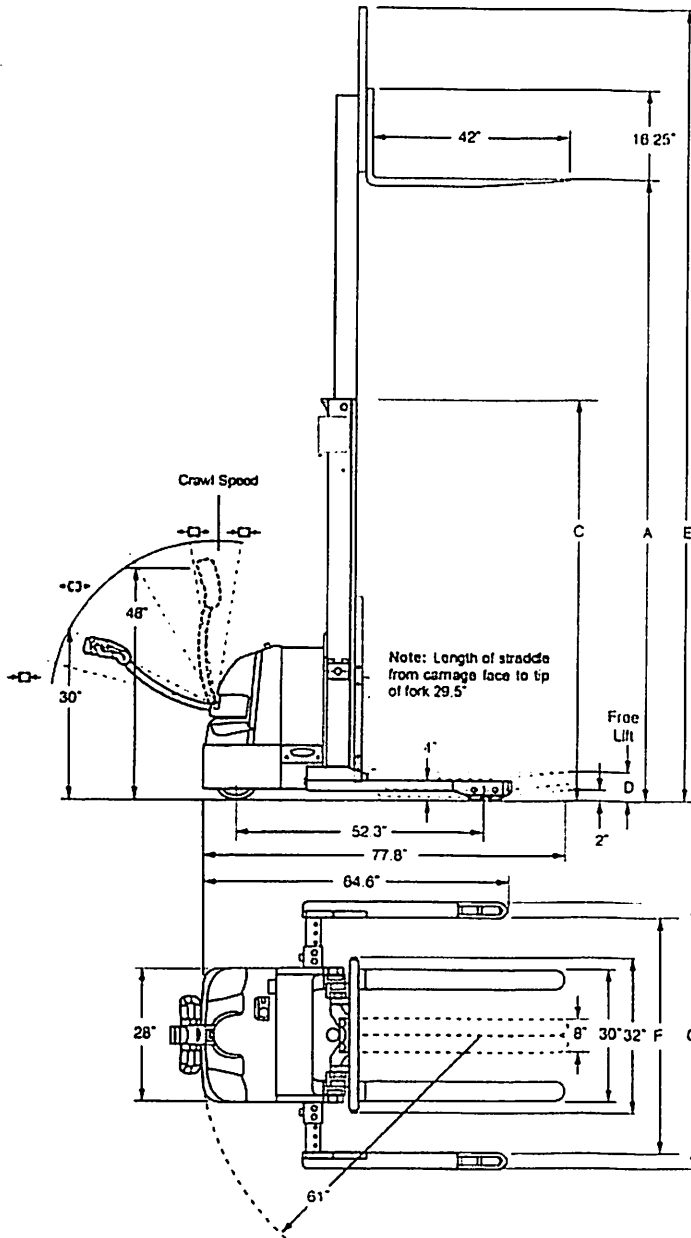

Aisle Guide

PDS25 - Right Angle Stacking

Load Width	Load Length		
	38"	40"	48"
36"	63.5"	63.5"	63.5"
40"	64.5"	64.5"	64.5"
48"	69.5"	69.5"	69.5"

For ease of use add 8" to aisle dimension listed

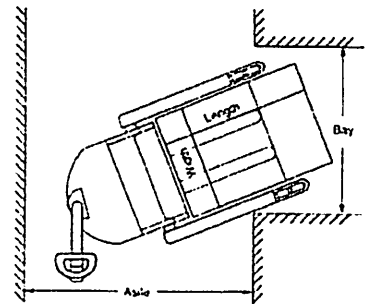

Aisle dimensions listed above assume the minimum bay width to be straddle OD plus 5" (2.5" on each either side of straddle leg). Straddle OD is the load width plus 8". Truck performance may vary due to application requirements and changes in model design.

Add: 2" to aisle for model PDS25-157 with triple stage mast.

Model #	Mast	Lift Height	Col Height	Free Lift	Ext Height w/LBR	Adjustable Straddle Leg 4" Increments		Weight Chassis Only
		A	C	D	E	F	G	
2500 Capacity @ 24" Load Center ITA Class II Fork Carriage								
PDS 25-106	Two Stage	106	71	6	142	38 to 50	44 to 56	1726
PDS 25-130	Two Stage	130	83	6	166	38 to 50	44 to 56	1816
¹ PDS 25-157	² TriMast	157	72	50	193	42 to 50	48 to 56	2156

¹Derate 500 lbs. above 142"

²Consult factory for derate

³Minimum straddle ID 42"

⁴Estimated shipping weight without battery

American Rescue Plan Project Submission Form

Project Name – H.I.M. Mobile Pantry Project

Primary Point of Contact – *The name and contact information for the person in your organization that should be contacted first about this project for more details.*

Lisa Richardson – CEO – 817-319-8070 – lisa@himcenter.org

Project Description – *A description of your project or item for purchase in 250 words or less, including why the project is needed and how that need will be met.*

Harvesting in Mansfield Food Bank is a 501(c)3 non-profit organization whose mission is to provide nutritious food with dignity, to all those in need of food assistance, while striving to change lives in the communities we serve by feeding the hungry and providing a hunger-free tomorrow for each of those individuals.

The Mobile Pantry Project is a continuation of the mobile service we offer to anyone in need on Tuesdays and Thursdays each week. We focus on the entire DFW metroplex area but our highest concentration of food assistance lies within Johnson and the deprived areas of Tarrant counties.

The Mobile Pantry Project is designed to provide 250 – 300 lbs. of food per household on a monthly basis. Currently, the registered number of monthly families is 6,300 and the individuals total 28,000. The Mobile Pantry provides an opportunity for all in need of nutritious groceries, to come, remain in their vehicle and we load the groceries into their vehicle. The mobile pantry provides a safe opportunity and provides an expeditious line so that more patrons may be served each week. Currently more than 1500 families are served weekly with groceries.

The project funding will be utilized to continue purchasing bulk foods from food distributors in order to continue to provide for all those in need. The current economic climate shows no relief in sight for lowering grocery costs or other cost of living expenses, forcing more families into our Mobile Pantry line.

Project Location – *Where your project will be performed, such as “500 feet along Main Street”, include maps, if available.*

H.I.M. Warehouse – 150 S. 6th Avenue, Mansfield, TX 76063

Project Budget – *A rough estimate of the budget required for your project.*

The total budget for a year’s worth of bulk groceries for the Johnson county residents is \$65,000.00. Please see attached budget.

Project Timeframe – *An estimate of how long it will take to start the project, how long the project will take to complete, and how long it will take to expend all funds related to the project.*

The Mobile Pantry Project is held weekly, twice per week and will continue throughout 2022 and 2023. The pantry will be expanded to include an evening each month for individuals not able to come during the day and a Saturday each month as well. The project is ongoing and will continue and funds related to the project will be expended in a 12 – 16 month period for bulk food purchases.



2022 MOBILE PANTRY BUDGET

12 months commencing 01/01/22 - 02/28/23

ITEM	COST	PALLETS REQUIRED	TOTAL \$'S	DOLLARS SPENT TO DATE
Vegetables - Canned (15 oz.) - Pallets	\$ 3,250.00	23	\$ 74,750.00	\$ 7,680.00
Protein/Meats - Frozen Pallets	\$ 4,215.00	22	\$ 92,730.00	\$ 5,860.00
Dry Staples - (Spaghetti/Mac/Rice)	\$ 2,869.00	25	\$ 71,725.00	\$ -
Dairy- (Eggs, Milk, Cheese)	\$ 3,135.00	20	\$ 62,700.00	\$ -
Assorted Fruits - Canned (15 oz.) - Pallets	\$ 3,360.00	18	\$ 60,480.00	\$ 6,720.00
	\$ -			\$ 20,260.00
			<u>\$ 362,385.00</u>	
			52	
			\$ 6,968.94	Weekly
Johnson County - 20% of entire serviced population of families			<u>\$ 65,000.00</u>	

Rachel Sitrler

From: Lisa Richardson <lisa@himcenter.org>
Sent: Monday, February 28, 2022 3:19 PM
To: kevin.dyer@grantworks.net; County Judge (public address)
Subject: American Rescue Plan Act Funding Requests
Attachments: 2022MOBILEPANTRYBUDGET.xlsx; AMERICANRESCUEPLAN-HIM.docx

Some people who received this message don't often get email from lisa@himcenter.org. [Learn why this is important](#)

*** External sender - use caution with links or attachments ***

Good Afternoon Kevin:

Please find attached our budget worksheet and our request for assistance from the American Rescue Plan Act.

The budget shows the total expenditure for bulk groceries for 2022 and then the percentage that is used for Johnson County. I applied for funds for the Johnson County residents we are currently serving, at this time, only. Each week brings new applicants through our Mobile Pantry line and these estimates for the food quantity allow for those patrons. The funding request is for bulk food purchases only and does not include any of our overhead or transportation expenses.

Approximately 20% of our patrons reside in Johnson County and that is reflected in the budget and the grant application. With the current economic budget climate, we anticipate about 30 new families through our lines weekly.

Please let me know if you have any questions and thank you so much for your assistance.

Graciously,

May faith give you the courage to dare to do great things today.

Lisa Richardson
H.I.M. Center Food Bank/Serving the DFW Metroplex
President & Chief Executive Officer
O – 817-453-FOOD (3663)
C – 817-319-8070



Hunger to Hope

American Rescue Plan Project Submission Form

Project Name - *A short name for your project, such as "Sewer Line Expansion along Main St."*

Hope Starts Here

Primary Point of Contact - *The name and contact information for the person in your organization that should be contacted first about this project for more details.*

Debbie Beeman

Director, Promises Community Ministries

140 NW Renfro, Burleson, TX 76028

817 295-9384

Email: dbeeman@firstburleson.org

Project Description - *A description of your project or item for purchase in 250 words or less, including why the project is needed and how that need will be met.*

We have been blessed with a new addition to our existing warehouse which allows us double the space for our clients to come in and self select their groceries. We were able to pay for the building and a new walk-in freezer for storage but need the following items to better serve our community.

Used refrigerated box truck with lift. Currently we only have a van which in the Summer is not safe to transport some items and keep them at a safe temperature. We have priced them at about \$50,000.00

- 1- Asber 82" glass door refrigeration unit to use for display/reach in when selecting cold items \$4,416.54**
- 1- Kelvinator 81" glass door freezer unit to use for display/reach in when selecting frozen items \$4,729.00**
- 1- Kenmore chest Freezer (for specialty items for large families only \$99**

Project Location - *Where your project will be performed, such as "500 feet along Main Street". Include maps, if available.*

140 NW Renfro, Burleson, TX 76028 (warehouse)

Project Budget - *A rough estimate of the budget required for your project.*

We had hoped to raise \$300,000.00 but only collected ~\$200,000.00 which has covered to building and the walk in freezer, along with shelving. The items above we still need but have exhausted our collected money. **The amount we would love to receive is \$59,244.54**

Project Timeframe - *An estimate of how long it will take to start the project, how long the project will take to complete, and how long it will take to expend all funds related to the project.*

Our building is complete, and we plan to open it officially on 5-2-2022

Rachel Sitler

From: Debbie Beeman <dbeeman@firstburleson.org>
Sent: Tuesday, March 15, 2022 3:38 PM
To: kevin.dyer@grantworks.net; County Judge (public address)
Subject: ARPA Funding Request
Attachments: ARPAFundingRequest.docx

Some people who received this message don't often get email from dbeeman@firstburleson.org. [Learn why this is important](#)

*** External sender - use caution with links or attachments ***

Hello,

Please see the attached grant request for our project. Please feel free to reach out to me if you need additional information.

Thank you for considering our request.

Debbie Beeman
Director, Promises Community Ministry
Part of First Baptist Church Burleson

PURSUING CHRIST | LOVING PEOPLE



DEBBIE BEEMAN | DIRECTOR OF PROMISES
817-295-9384 | DBEEMAN@FIRSTBURLESON.ORG
PROMISES COMMUNITY MINISTRIES

American Rescue Plan Project Submission Form

Project Name - *A short name for your project, such as "Sewer Line Expansion along Main St."*

Refurbishing a single wide

Primary Point of Contact - *The name and contact information for the person in your organization that should be contacted first about this project for more details.*

Lisa Schwarz, 817-798-3441
lisa@crazy8ministries.com

Project Description - *A description of your project or item for purchase in 250 words or less, including why the project is needed and how that need will be met.*

We bought our fourth campus in 2021 and it came with four structures. Two of them were move in ready and the other two needed a lot of "TLC." We refurbished one of the two in 2021 and we are now ready to start on the last one. We have filled the first three structures with 3 women, 4 teens, and 3 children. This last structure is a two-bedroom single wide that could house 2-5 people (depending on the family dynamics) upon completion.

This campus is houses people who are in their last phase of our program. It provides them with an extra year of aid through affordable housing while building up their savings. These are two crucial components to moving our residents into total independence.

Project Location - *Where your project will be performed, such as "500 feet along Main Street". Include maps, if available.*

1612 E 2nd St
Cleburne, TX 76031

This single wide is positioned in the back of the acre.

Project Budget - *A rough estimate of the budget required for your project.*

Last year's refurbishing came in around \$45,000 and we are projecting around the same for this one. This includes new electrical, HVAC, roof, and structure corrections as well as the aesthetics of the inside. We will also need to build some sort of porch for the entrance. In addition, we will need to spend about \$2,000-\$3,000 on getting it move-in ready. This includes furniture, appliances, curtains, shower rods and curtains, dishes, cutlery, etc.

Project Timeframe - *An estimate of how long it will take to start the project, how long the project will take to complete, and how long it will take to expend all funds related to the project.*

We NEED to start moving forward on this project in 2022 as we have current residents who will be ready for this next step within the next 6 months. The project itself will take about 3 -4 months to complete. We intend to have it move-in ready by the fall of 2022.

Paula G. Reid

From: Lisa Schwarz <lisa@crazy8ministries.com>
Sent: Friday, January 21, 2022 8:54 AM
To: kevin.dyer@grantworks.net; County Judge (public address)
Subject: Fwd: American Rescue Plan Act Funding Request
Attachments: Crazy8 Ministries_Project 1_Foundation.pdf; Crazy8 Ministries_Project 2_Connections Building.pdf; Crazy8 Ministries_Project 3_Single Wide.pdf

Follow Up Flag: Follow up
Flag Status: Completed

Categories: To Do!

Some people who received this message don't often get email from lisa@crazy8ministries.com. [Learn why this is important](#)

*** External sender - use caution with links or attachments ***

Mr. Dyer and Judge Harmon,

Please see the (three) attached application forms for the ARPA funding on behalf of Crazy8 Ministries. We have three projects (needs) so I outlined them each on their own applications. Let me know if you need any more information in regard.

It is a pleasure to serve in Johnson County and we appreciate your consideration.

Lisa Schwarz
Crazy8 Ministries

Lisa Schwarz C.B.C. C.P.C. B.H.C.
Founder, CEO
Crazy8 Ministries
Office: 817-202-8408
<https://crazy8ministries.com/>

Lisa Schwarz C.B.C. C.P.C. B.H.C.
Founder, CEO
Crazy8 Ministries
Office: 817-202-8408
<https://crazy8ministries.com/>

American Rescue Plan Project Submission Form

Project Name- Road Repaving

Primary Point of Contact - Jerri Vaughn, Executive Director 817-558-7171
vaughnjerri@hotmail.com

Project Description - We propose the repaving of the road leading to the **Family Crisis Center**. The road was repaved about five years ago. After the significant freezing weather and snowstorm in February of 2021, it started to develop cracking and many large potholes. To repair the potholes and repave 910 -foot -long road, we have an estimate of \$19,000. That is for a single layer. To repave it with the recommended two coats, the estimate is \$30,000. That includes two levels of tar and two levels of gravel. This is work that must be done to enable our clients and staff to safely travel to the agency. Our agency serves victims of family violence and sexual assault. The coronavirus has exacerbated some of the biggest risk factors for family violence. Families are often under financial pressures and the continued economic uncertainty has hindered their ability to cope. This may cause events to escalate. For some women and children, home is not a safe place. We serve approximately 1,200 people per year at our agency. We have clients who need shelter, however, many of our clients come for counseling, parenting classes, and case management. We received funding to help victims with housing, but they then must come in for case management. The last thing they need is to ruin a tire due to a pothole when they are reaching out for help.

Project Location – The road repairs will be on the 910 feet of private road leading to our facility at 660 County Road 903.

Project Budget – The road will cost \$30,000. This includes two layers of tar and two layers of gravel.

Project Timeframe – The work can start as soon as possible, allowing for weather. The project will be completed about two days. The funds will be expended as soon as the work is complete.

Rachel Sitler

From: Jerri Vaughn <vaughnjerri@hotmail.com>
Sent: Monday, April 11, 2022 11:26 AM
To: kevin.dyer@grantworks.net; County Judge (public address)
Subject: American Rescue Plan Project Submission Form Johnson County Family Crisis Center
Attachments: American Rescue Plan Project Submission Form.docx

Categories: ARPA

Some people who received this message don't often get email from vaughnjerri@hotmail.com. [Learn why this is important](#)

*** External sender - use caution with links or attachments ***

American Rescue Plan Project Submission Form

Project Name - A short name for your project, such as "Sewer Line Expansion along Main St."

Main Campus Foundation Repair

Primary Point of Contact - The name and contact information for the person in your organization that should be contacted first about this project for more details.

Lisa Schwarz, 817-798-3441
lisa@crazy8ministries.com

Project Description - A description of your project or item for purchase in 250 words or less, including why the project is needed and how that need will be met.

Our Crazy8 Ministries main office has major cracks throughout the building due to the foundation shifting. We have had two companies come inspect and both have confirmed that our foundation needs some major attention. This building houses our administrative offices, but more importantly is where our community counseling services take place. These repairs are necessary to ensure the safety of our community clients and staff, as well as allowing us to continue providing our FREE counseling services to Johnson County residents and students.

We will also need to repair some cracks throughout the building and then paint those areas.

Project Location - Where your project will be performed, such as "500 feet along Main Street". Include maps, if available.

1100 W FM 917
Joshua, TX 76058

The large main house is the one needing repaired.

Project Budget - A rough estimate of the budget required for your project.

Foundation: Our quotes have come in between \$15,040.00 and \$17,096.00 depending on what materials we pick as well as the warranty.
Walls/Cracks/Paint: \$3000-\$5000

Project Timeframe - An estimate of how long it will take to start the project, how long the project will take to complete, and how long it will take to expend all funds related to the project.

We have this project placed at high priority and hope to have the funding to begin as soon as possible this year. The foundation should only take a week or so to repair and then we will begin the inside repairs to the walls. We hope to complete the entire project by April 1, 2022

American Rescue Plan Project Submission Form

Project Name - *A short name for your project, such as "Sewer Line Expansion along Main St."*

Revenue Recovery for 2020

Primary Point of Contact - *The name and contact information for the person in your organization that should be contacted first about this project for more details.*

Barbara Lane - Board President

Phone: 817-641-4908

Email: cleburnefca@gmail.com

Project Description - *A description of your project or item for purchase in 250 words or less, including why the project is needed and how that need will be met.*

Cleburne Friends of the Cultural Arts is a 501(c)(3) nonprofit in Johnson County. We operate the JN Long Cultural Arts Center in Cleburne to fulfill our mission to enhance the quality of life in Cleburne and Johnson County by building a strong cultural arts community and increasing public awareness of the arts. We provide a space for over twenty member groups and a hundred member artists to hold meetings and classes. By reducing artists overhead expenses they can make their classes affordable in our community

We host six to eight art exhibits annually along with being the home to the Texas Woodcarvers Guild Museum and a Transportation Museum. We are open for free to the public and attract visitors from across the state.

During 2020 the National COVID Shutdown and continuing concern for public health effectively crippled our operations, including summer art classes. In the summer of 2019 we had 7 instructors, teaching 11 classes to over 300 youth.

While we are surviving as a nonprofit today we still struggle to reinstate some of these programs, including summer art classes. Recovering the financial losses suffered in 2020 would allow us to experience a 'full' recovery and bring these programs back to the community.

Project Location - *Where your project will be performed, such as "500 feet along Main Street ". Include maps, if available.*

JN Long Cultural Arts Center is located at 425 Granbury St in Cleburne. We serve Cleburne and Johnson County and have visitors to our exhibits and museums from across the metroplex.

Project Budget - *A rough estimate of the budget required for your project.*

Revenue loss from 2019 to 2020 was \$21,000

Project Timeframe - *An estimate of how long it will take to start the project, how long the project will take to complete, and how long it will take to expend all funds related to the project.*

Funds to replace lost revenue will be used immediately to assist with payment of wages and utilities. More broadly having these funds will allow us to resume programs, including youth summer art classes, as early as this year. Advertising to attract participants should begin by the end of May in order to get flyers into the backpacks of Cleburne ISD students.

Rachel Sitler

From: JN Long Cultural Arts Complex <jnlongculturalarts@gmail.com>
Sent: Saturday, March 19, 2022 3:15 PM
To: kevin.dyer@grantworks.net; County Judge (public address)
Subject: American Rescue Plan Act Funding Request
Attachments: CFCA- AARP Funding Request.pdf

Some people who received this message don't often get email from jnlongculturalarts@gmail.com. [Learn why this is important](#)

*** External sender - use caution with links or attachments ***

Good Afternoon,

I am submitting a request for American Rescue Plan Act Funding for the 501(c)(3) nonprofit Cleburne Friends of the Cultural Arts (CFCA) dba JN Long Cultural Arts Center. We are requesting assistance with the loss of revenue in 2020. Prior to COVID we were a debt free nonprofit. As a result of the financial burden created by the pandemic we assumed a \$25,000 loan with the SBA. Please find the form submission attached to this email.

Thank you,

Susan Ford | Executive Director
JN Long Cultural Arts Center, 425 Granbury Street, Cleburne TX
817-641-4908 | jnlongculturalarts.org



a 501(c)(3) Nonprofit Organization

Mission: to enhance the quality of life in Cleburne and Johnson County by building a strong Cultural Arts Community and increasing public awareness of the arts.

Rachel Sitrler

From: Maggard Patty <maggardp@gmail.com>
Sent: Thursday, April 7, 2022 3:06 PM
To: kevin.dyer@grantworks.net
Cc: County Judge (public address)
Subject: JCCS American Rescue Plan Project Submission Form

Categories: ARPA

Some people who received this message don't often get email from maggardp@gmail.com. [Learn why this is important](#)

*** External sender - use caution with links or attachments ***

Project Name- Johnson County Campus Crime Stoppers

Primary Point of Contact- Patty Maggard- President Johnson County Crime Stoppers
maggardp@gmail.com
817-992-8570

Project Description-

Children deserve to feel safe. Unfortunately, that is often not the case evidenced by rampant school violence. Campus Crime Stoppers gives a child a safe avenue to alert officials of disturbing behavior, remain anonymous, and receive a reward.

To let students and adults know about the program our plan is to produce a professional video using teenage actors demonstrating the anonymous tip-reward process. The video will be shown to pre-teen and teenage students at school and at other venues. An added benefit of telling the story with video is it would allow nearly anyone to make the presentation and media is our present language.

Creating the video requires serious fund raising on our part, but that hasn't been successful during the pandemic. Revenue from this grant would allow JCCS to no longer delay our mission and to move forward to launch this awareness campaign.

The expected results of this campaign are to empower students to protect themselves and others, to reduce campus crime, to create a safer learning environment, and to deter delinquency, weapons, drugs, bullying, etc. in the school and community environment.

Project Location- The video will be shown at secondary schools throughout Johnson County, TX. The video will also be available to other venues serving teenagers.

Project Budget- \$20,000.00 An estimate of \$18,000 Produce video (Agency Habitat-Advertising Agency in Ft.Worth)
An estimate of \$2,000 Printing school posters

Project Timeframe- Project development could begin as soon as funds are available. The production phase is estimated to take 8 to 10 months.

Thank you for this opportunity and consideration of our project.

American Rescue Plan Project Submission Form

Project Name- HOPE Medical/Dental Clinic

Primary Point of Contact – Diane Westcott, Ex Dir 682-916-4131
Sandy Ledbetter, Treasurer 817-933-1272

Project description – Refurbishing of existing clinic space.

Project description – The clinic has been located in the old fellowship hall at the Cleburne First Seventh Day Adventist Church for 16 years. The space was remodeled to accommodate the clinic. The clinic is in need of painting and the carpet in the waiting area needs to be replaced. The clinic front door also needs to be replaced due to wind damage. We also need new signage for the clinic.

Project location- 111 Meadowview Drive, Cleburne, Texas 76033

Project Budget - \$10,000

Project time frame- We would like to be completed by the end of this year.

Rachel Sitrer

From: Diane Westcott <pdwestcott@hopeclinicleburne.com>
Sent: Tuesday, March 22, 2022 10:33 AM
To: kevin.dyer@grantworks.net
Cc: County Judge (public address)
Subject: Funding Request
Attachments: American Rescue Plan Project Submission Form.docx

*** External sender - use caution with links or attachments ***

Thank you for considering our clinic for funding. Please feel free to call with any questions.

Sincerely,

Diane Westcott, Executive Director

682-916-4131

Sent from [Mail](#) for Windows

American Rescue Plan Project Submission Form

Project Name- HOPE Medical/Dental Clinic

Primary Point of Contact – Diane Westcott, Ex Dir 682-916-4131
Sandy Ledbetter, Treasurer 817-933-1272

Project description – Replacing old computers.

Project description – The clinic needs to replace its old file server and 10 workstations. Our file server is over 10 years old. The workstations are also old and very slow.

Project location- 111 Meadowview Drive, Cleburne, Texas 76033

Project Budget - \$10,000

Project time frame- We would like to be completed by the end of this year.

Rachel Sitrler

From: Diane Westcott <pdwestcott@hopecliniccleburne.com>
Sent: Tuesday, March 22, 2022 12:18 PM
To: kevin.dyer@grantworks.net
Cc: County Judge (public address)
Subject: RE: Funding Request
Attachments: American Rescue Plan Project Submission Form 2.docx

Some people who received this message don't often get email from pdwestcott@hopecliniccleburne.com. [Learn why this is important](#)

*** External sender - use caution with links or attachments ***

This is another project we are looking for funding for.
Thank you again,
Diane Westcott, Executive Director

Sent from [Mail](#) for Windows

From: [Paula G. Reid](#)
Sent: Tuesday, March 22, 2022 11:23 AM
To: [Diane Westcott](#)
Subject: RE: Funding Request

Received.

Thank you,

Paula Reid

Administrative Assistant to
County Judge Roger Harmon
2 N Main, RM 120
Cleburne, Texas 76033
817-556-6360

From: Diane Westcott <pdwestcott@hopecliniccleburne.com>
Sent: Tuesday, March 22, 2022 10:33 AM
To: kevin.dyer@grantworks.net
Cc: County Judge (public address) <countyjudge@johnsoncountytexas.org>
Subject: Funding Request

*** External sender - use caution with links or attachments ***

Thank you for considering our clinic for funding. Please feel free to call with any questions.

Sincerely,

Diane Westcott, Executive Director

682-916-4131

Sent from [Mail](#) for Windows

American Rescue Plan Project Submission Form

Project Name – A short name for your project, such as “Sewer Line Expansion along Main Street.”

Court Appointed Special Advocate (CASA) Volunteer Recruitment Campaign

Primary Point of Contact – The name and contact information for the person in your organization that should be contacted first about this project for more details.

Danielle Elliott, Executive Director

817-558-6995 x113

CASA of Johnson County

Project Description – A description of your project or item for purchase in 250 words or less, including why the project is needed and how that need will be met.

The project includes advertising for volunteers through local radio stations for the purpose of recruiting community members who are interested in becoming trained volunteer advocates for our children in foster care from Johnson County. Radio advertising has been seen as successful in the past; however, the cost is higher than our limited budget allows. Our budget has been further limited due to inaccessible fundraising efforts over the last two years due to COVID-19 restrictions. This project is needed because our volunteer numbers are down, however children continue to come into care due to abuse and/or neglect which means we are unable to support advocacy efforts for some of these children. Our organization has lost volunteers through COVID-19 deaths, and volunteer resignations due to various personal issues related in some way to COVID-19.

Project Location – Where your project will be performed, such as “500 feet along Main Street”. Include maps, if available.

The project will be performed through radio advertising as well as banner ads (if available) through local radio stations in the Johnson County/DFW area, throughout the remainder of 2022.

Project Budget – A rough estimate of the budget required for your project.

\$7,000

Project Timeframe – An estimate of how long it will take to start the project, how long the project will take to complete, and how long it will take to expend all funds related to the project.

The recruitment project would begin (approximately) in May continuing throughout the Summer into the Fall as our volunteer training classes commence once per quarter.

Thank-you
for your Consideration
Danielle Elliott

Rachel Sitler

From: Danielle Elliott <danielle@casajohnsoncounty.org>
Sent: Monday, April 11, 2022 4:54 PM
To: kevin.dyer@grantworks.net; County Judge (public address)
Subject: ARPA Funding Request
Attachments: CASA of Johnson County ARPA Funding Request 2022.pdf

Sensitivity: Confidential

Categories: ARPA

Some people who received this message don't often get email from danielle@casajohnsoncounty.org. [Learn why this is important](#)

*** External sender - use caution with links or attachments ***

Please see attached the completed ARPA Funding request (page 2) for consideration from CASA of Johnson County.

Thank you,
Danielle Elliott
Executive Director



210 Featherston
P.O. Box 3462
Cleburne, TX 76033
(817) 558 6995 Ext. 113

CONFIDENTIALITY NOTICE: This email communication and any attachments may contain confidential and privileged information for the use of the designated recipients named above. This transmission is strictly confidential. If you are not the intended recipient of this message, you may not disclose, print, copy or disseminate this information. If you have received this in error, please reply and notify the sender (only) and delete the message. Unauthorized interception of this email is a violation of federal criminal law.

American Rescue Plan Act Funding Request:

February 9, 2022

Project Name:

Project: Be the Answer in Johnson County

Primary Point of Contact:

Answer International Foundation

Cindy Cooley, Director of Global Partners

C: 903.450.6220

Cindy.Cooley@answerinternational.org

Project Description:

Answer International is an anti-human trafficking organization that fights to prevent human slavery domestically and around the world. Our Foundation works to prevent, rescue, and transform human trafficking survivors by offering life-saving services that liberates men, women and children giving them a pathway into a life of freedom. Answer International builds partnerships with those who provide food, housing, medical care, trauma counseling, education, medical care, and job training, essential for building resiliency while providing on-going support around the world. One hundred percent of the revenue we fund raise, goes toward preventative measures, rescue efforts or on-going support of human trafficking survivors. Much of what Answer International has contributed to the crisis of human trafficking has gone abroad. Our goal is to vastly increase our domestic impact by aligning the fruits of our mission directly with Johnson County.

Answer International 's plan to increase impact and partner with community stakeholders will require a stronger marketing strategy to promote AI's mission to end human slavery. This will include but not limited to:

- Complete the re-branding process of Answer International's logo
- Redesign of organization website
- Videographer/photographer for refreshed website and scheduled events
- Digital marketing /social media management/advertising tools with new logo
- Promotional items used at community outreach events
- Laser Jet Printer/copier/scanner necessary for everyday operations

Project Location:

Answer International Foundation will partner with stakeholders and bring awareness to the Johnson County area. This would include but not limited to: awareness and partnerships with schools, churches, hospitals, child advocacy center, pregnancy centers, family crisis centers/shelter, homeless outreach, law enforcement agencies and county governments. Preventative and rescue efforts to any victim or survivor need in Johnson County.

Project Budget:

- | | |
|--|---------------|
| • Re-brand logo design and custom website build | \$3000 |
| • Videographer/photographer (website content) | \$500 |
| • Digital Marketing/social media/advertising tools | \$300 |
| • Promotional Items/business cards/letterhead | \$700 |
| • Laser Jet Printer/copier/scanner | \$550 |
| Total estimated budget: | \$5050 |

Project Timeframe:

Project: Be the Answer in Johnson County will begin immediately upon receipt of funds. Estimated completion time frames:

- Laser Jet Printer completed within 30 days
- New logo and Re-brand finalized completed within 90 days
Promotional items/business materials
- Website rebuild and go live within 180 days
- Photography/videos for website within 180 days

The project would have an estimated completion date of January 1, 2023. Answer International will be able to make significant impact with the stakeholders, potential victims, and human trafficking survivors in Johnson County by presenting a clear understanding of who we are, how to reach out, and how we empower all involved to make their next steps. Thank you very much for your consideration with funding our project.

Rachel Sitrler

From: Cindy Cooley <Cindy.Cooley@answerinternational.org>
Sent: Wednesday, February 9, 2022 4:16 PM
To: kevin.dyer@grantworks.net; County Judge (public address)
Subject: American Rescue Plan Act- Funding Request
Attachments: American Rescue Plan Act- Funding Request.docx

Some people who received this message don't often get email from cindy.cooley@answerinternational.org. [Learn why this is important](#)

*** External sender - use caution with links or attachments ***

Thank you for your consideration. Please see attached Funding Request Application.

Cindy Cooley

Director of Global Partners

O: 817.289.8213

C: 903.450.6220

Answerinternational.org



Judge Harmon,

Open Door Food Pantry
6601 CR 912
Joshua Texas 76058

ODFP Expansion Project

My name is Barry Gee, and I am the CFO for Open Door Food Pantry (ODFP). ODFP is the largest non-profit (501c3) food bank distribution center in Johnson County. Each year we give away over 4.5 million pounds of food to the residents of Johnson County. ODFP distributes food every other Saturday at 6601 CR 912 for a total of 26 outreaches. ODFP also supplies other food pantries/churches in the Johnson County area.

We would like the opportunity to apply for funding to build an additional 7,500 sq.ft. warehouse with freezers/coolers, concrete for our parking lots, and two additional forklifts. This would allow ODFP to expand our distribution, onsite food storage to prevent spoilage and waste, and to better serve Johnson County and its people. This project will take 9 – 12 months to complete.

Cost of the 7500 sq ft. metal warehouse at \$ 105.00 per sq. ft. ----- This includes all electrical, plumbing, insulation, restrooms, office space. It also includes the loading dock and approved septic system	\$ 790,000
4– 1000 ft walk in coolers/freezers	\$ 180,000
Concrete existing parking lot and around new warehouse	\$ 275,000
2 – forklifts	\$ 42,000
Metal fencing to secure property	\$ 58,000
Total Grant Request	\$ 1,345,000

Thank you, sir, for your consideration for this grant.

Barry Gee

Chief Financial Officer
Open Door Experience
Troy Brewer Ministries
Open Door Food Pantry
cfo@opendoorexperience.com
cell : 817-988-1685

Rachel Sitler

From: Rexann Knowles
Sent: Wednesday, March 2, 2022 4:07 PM
To: Rachel Sitler
Subject: FW: Grant proposal for Open Door Food Pantry
Attachments: Grant letter 2-30-22.docx

From: Chief Financial Officer <cfo@opendoorexperience.com>
Sent: Sunday, January 30, 2022 3:33 PM
To: County Judge (public address) <countyjudge@johnsoncountytexas.org>; kevin.dyer@grantworks.net
Subject: Grant proposal for Open Door Food Pantry

Some people who received this message don't often get email from cfo@opendoorexperience.com. [Learn why this is important](#)

*** External sender - use caution with links or attachments ***

Kevin,

Here is a copy of our grant proposal.

I will try to contact you one day this week or feel free to reach out to me.

Thank you

Barry Gee

Chief Financial Officer @

Open Door Experience

Troy Brewer Ministries

cfo@opendoorexperience.com

cell : 817-988-1685

Project Name	Construction/Non-Construction	Estimated Cost	# of People Impacted	Duration of Impact	Request	Efficiency Score	Category
Chisholm Trail Outdoor Museum	Construction	\$245,000	50000	30	New cabins with restrooms, signage, replacement of teepees	0.16	Tourism and Culture
HOPE Medical/Dental Clinic	Non-construction	\$20,000	5000	10	Replacement of old computers and refurbishment of clinic space (paint walls, replace carpet & door, new sign)	0.40	Health Care
Facility Modifications for Behavioral/Physical Health Primary Care - PVC	Construction	\$150,000	2500	40	Renovations to allow for primary physical medical care; environmental improvements for better behavioral health care outcomes	1.50	Mental Health
Johnson County Sheriff's Posse Arena Restroom & City Sewer Addition	Construction	\$375,000	5500	40	Add public restroom to an outdoor arena	1.70	Tourism and Culture
JN Long Cultural Arts Center 2020 Revenue Recovery	Non-construction	\$21,000	2000	3	Cover lost revenue from 2020, resume summer youth art classes	3.50	Tourism and Culture
H.I.M. Mobile Food Pantry	Non-construction	\$65,000	15000	1.01	A year of bulk food purchases for distribution to Johnson County residents	4.29	Food Support
Open Door Food Pantry	Construction	\$1,345,000	6400	30	Construction of food distribution warehouse	7.01	Food Support
A Change for Christ Community Center and Gymnasium	Construction	\$1,300,000	6000	30	Construction of Community Center & Gymnasium	7.22	Community Support
Next Step Women's Center	Construction	\$2,715,400	10000	30	Construction of medical center to provide free prenatal care to pregnant women	9.05	Health Care
Hope Starts Here (Promises)	Non-construction	\$59,245	400	12	Refrigerated box truck, glass door refrigeration and freezing units, chest freezer	12.34	Food Support
Texas Health Resources Huguley and Burleson ISD School Based Clinic	Construction	\$1,000,000	1240	50	Construct in-school teaching clinic with 4-6 rooms and lead walls for X-Rays	16.13	Health Care
Pathway Fiber to the Premise	Construction	\$1,950,000	5000	23	Expansion of Pathway Fiber Network to various underserved locations	16.96	Fiber Infrastructure
Spark Life Center	Construction	\$2,220,000	3000	30	Construction of community multipurpose center	24.67	Community Support
Texas Health Huguley Mobile Health Clinic	Non-construction	\$750,000	2500	12	Replacement of a bus serving as a base for a mobile clinic	25.00	Health Care
Texas Health Navigation Services	Non-construction	\$2,400,000	30000	3	Connect affected Johnson County residents with resources to assist them	26.67	Health Care
Johnson County Emergency Services District No. 1 - Ambulances	Non-construction	\$500,000	900	15	SUV response vehicles, EMS equipment	37.04	Health Care
Blue Water Oaks Wastewater Treatment Plant Replacement	Construction	\$750,000	500	30	Complete replacement of old water treatment plant past its useful life	50.00	Water
City of Rio Vista Sewer Plant Expansion	Construction	\$3,660,000	2400	30	Expansion of wastewater treatment plant in Rio Vista; tripling capacity and allowing up to 800 more residential connections	50.83	Water
Alvarado Helping Hands for Jesus T.E.A.M. Center	Construction	\$1,750,000	1050	20	New building for food distribution, refrigerated food truck, pick-up truck	83.33	Food Support
Center for Autism Spectrum Disorder	Non-construction	\$1,712,600	1000	20	Purchase of the building that is currently being rented, scholarships for financially disadvantaged students	85.63	Mental Health
Reinspire Youth and Young Adult Resource Center	Non-construction	\$75,000	600	1	Rent a space to serve as a resource center for at-risk youth services, provide those services	125.00	Mental Health
Crazy 8 Ministries	Construction	\$220,000	64	20	Congregate counseling facility, renovation of affordable housing, and repairs to existing counseling areas	171.88	Mental Health
Reinspire Young Adult Housing	Construction	\$725,000	16	40	Construct affordable housing for youth working on the transition to supporting themselves	1,132.81	Mental Health & Housing